

C ↑

C (1 : 2)

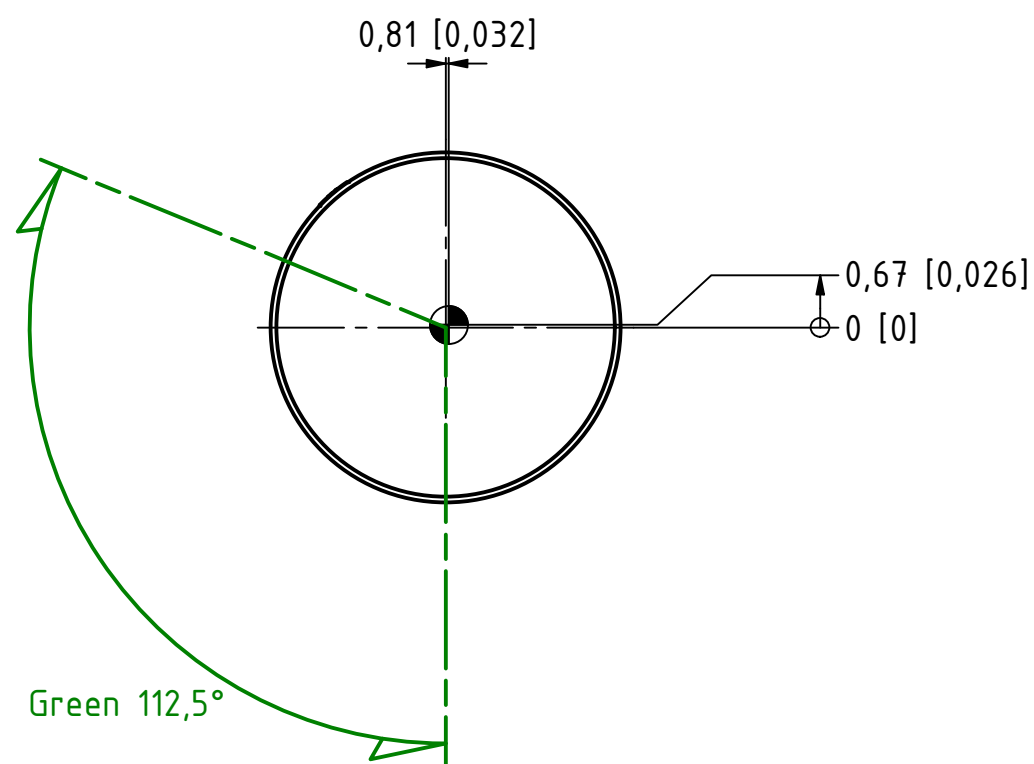
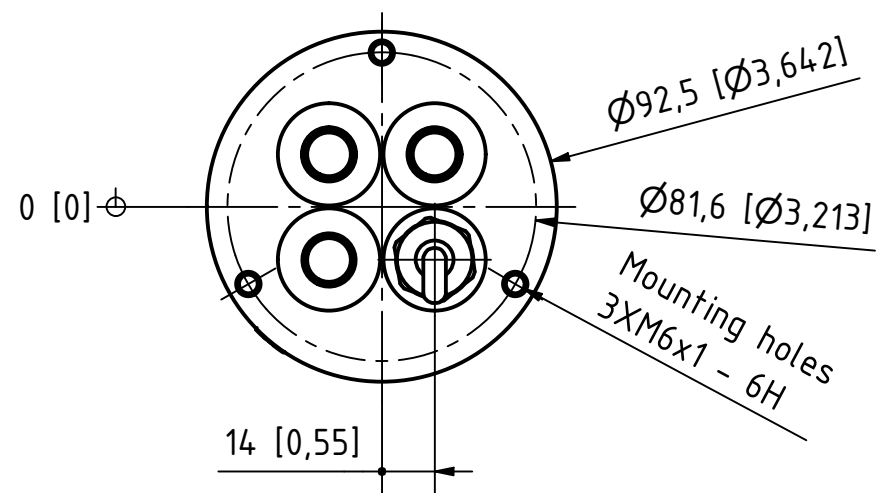

Dimensions : Millimetres [Inches]
 Estimated weight: 0,8 kg (1,8 lbs)

TITLE: 301-008-WH-UL 2nm Stbd, white ceramic coated, UL On a 400-035 Promount base, Cable Down					
DRAWING No.: 301-008-WH-UL			Sheet No.: 1	DRAWN BY: LSA	
SCALE: 1 : 2	SIZE: A3	REV. NO.:	TOLERANCES: DS/ISO 2768-f	REVIEWED BY:	CREATION DATE: 08-06-2023
MATERIAL DESCRIPTION: Alu. EN6082, Acrylic			(25µ) Silver anodized according to EN ISO 7599 (50µ) Black anodized according to MIL-A 8625F		

This Drawing, and the information within, is the property of Lopolight ApS and may not be used in any form without express permission there from. Lopolight reserves the right to change this drawing and assumes no liability for the information communicated herein. Use of dimensions and other information in this drawing is at the users own risk.



Lopolight ApS
 Bakkegaardsvej 513
 DK-3050, Humlebaek
 Denmark
 www.lopolight.com

Tel: (+45) 32 48 50 30
 info@lopolight.com

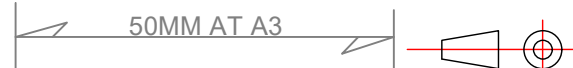

A B C D E F G H I J

1
2
3
4
5
6
7
8

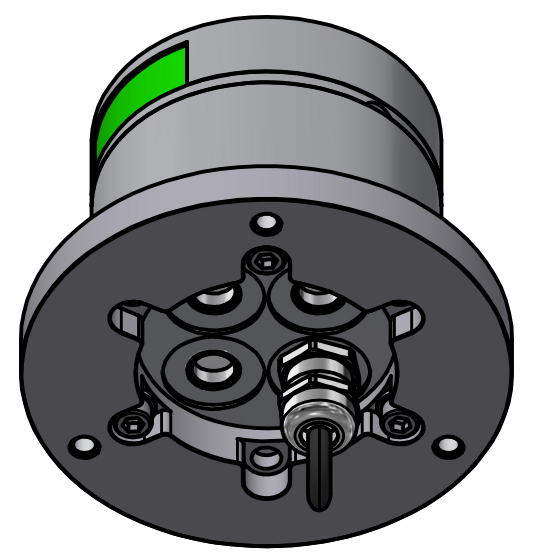
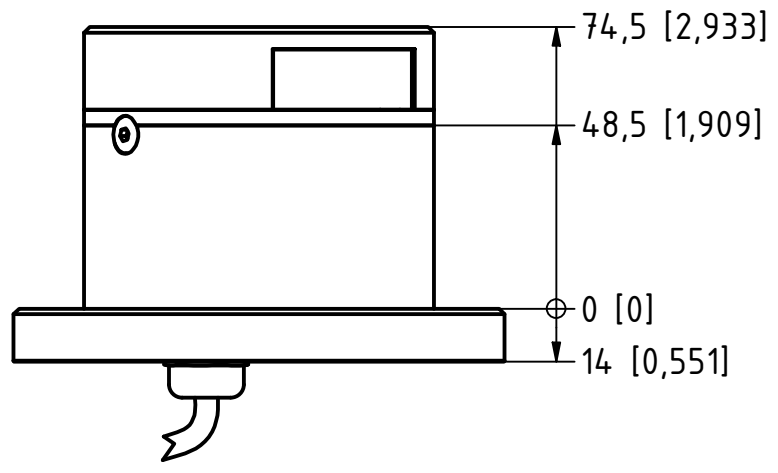
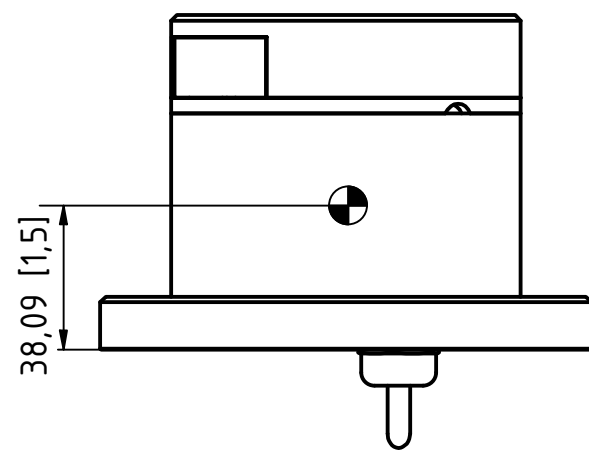
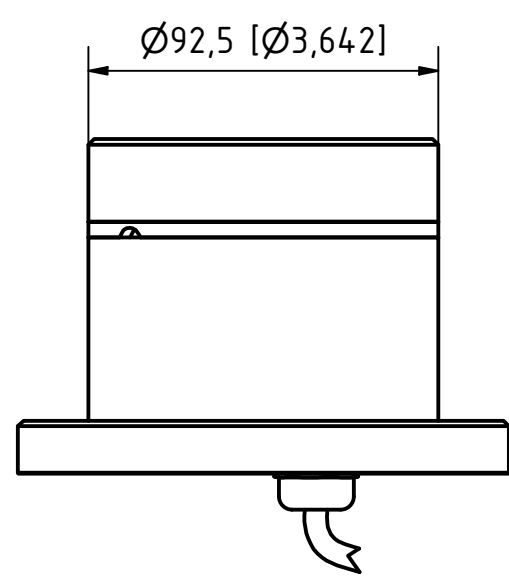

D ↑

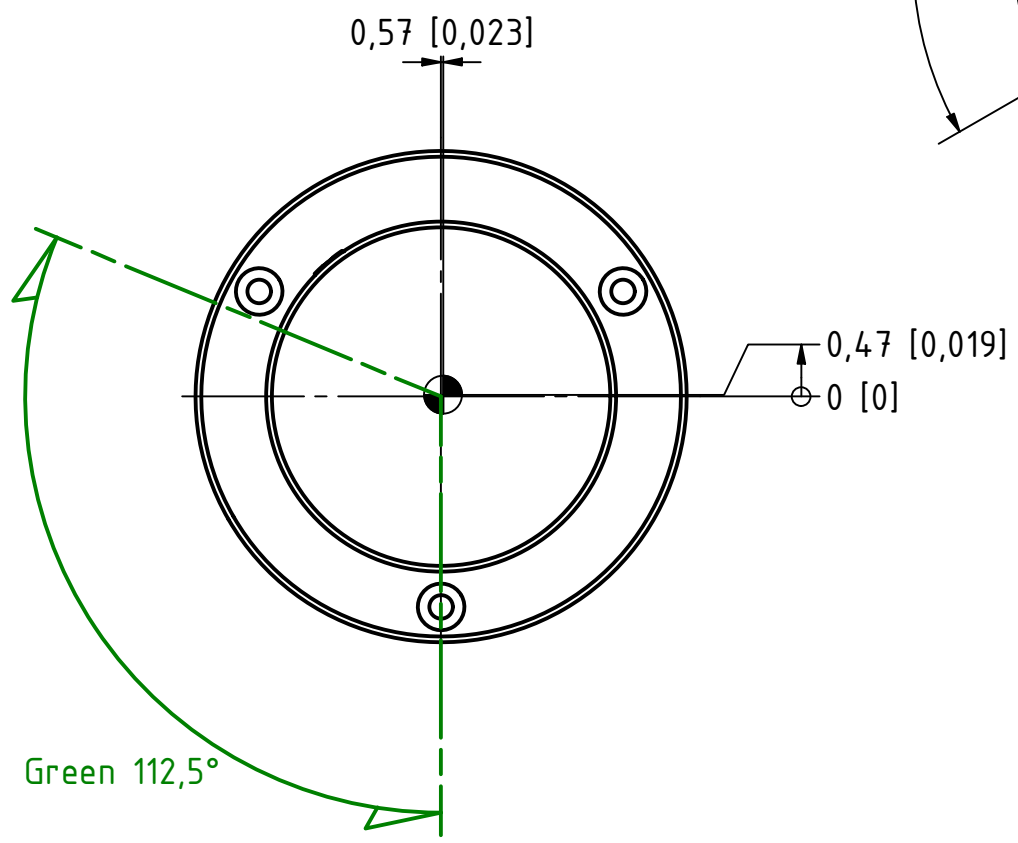
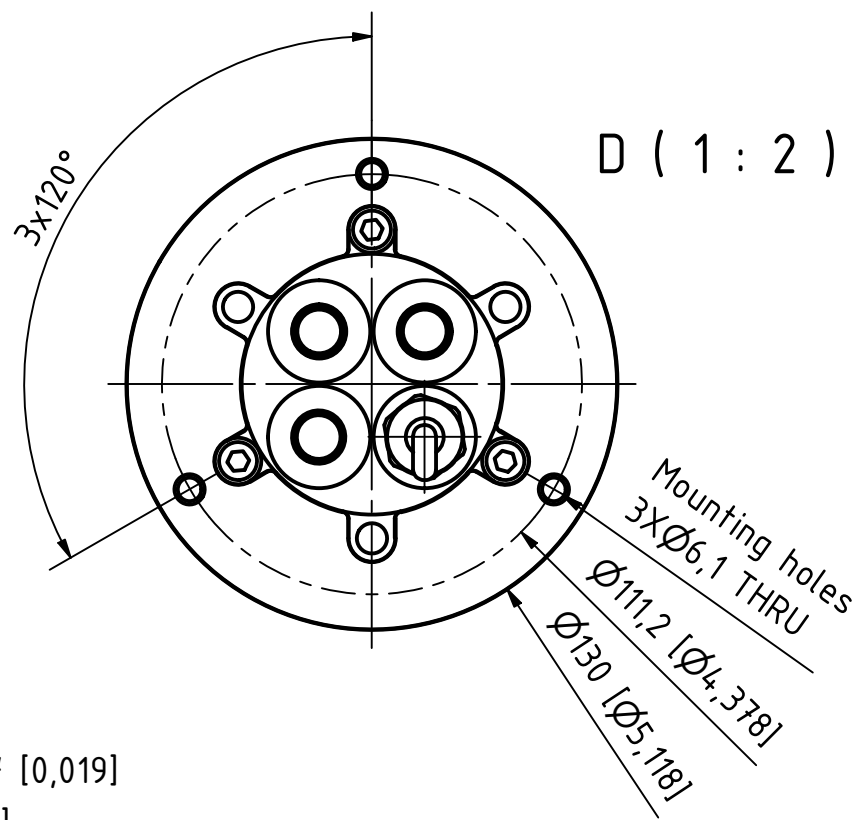

Dimensions : Millimetres [Inches]
Estimated weight: 1,1 kg (2,5 lbs)

TITLE: 301-008-WH-UL 2nm Stbd, white ceramic coated, UL On a 400-035 Promount base and 400-401 circular aluminium baseplate					
DRAWING No.: 301-008-WH-UL			Sheet No.: 2	DRAWN BY: LSA	
SCALE: 1 : 2	SIZE: A3	REV. NO.:	TOLERANCES: DS/ISO 2768-f	REVIEWED BY:	CREATION DATE: 08-06-2023
MATERIAL DESCRIPTION: Alu. EN6082, Acrylic					
(25µ) Silver anodized according to EN ISO 7599 (50µ) Black anodized according to MIL-A 8625F					

This Drawing, and the information within, is the property of Lopolight ApS and may not be used in any form without express permission there from. Lopolight reserves the right to change this drawing and assumes no liability for the information communicated herein. Use of dimensions and other information in this drawing is at the users own risk.

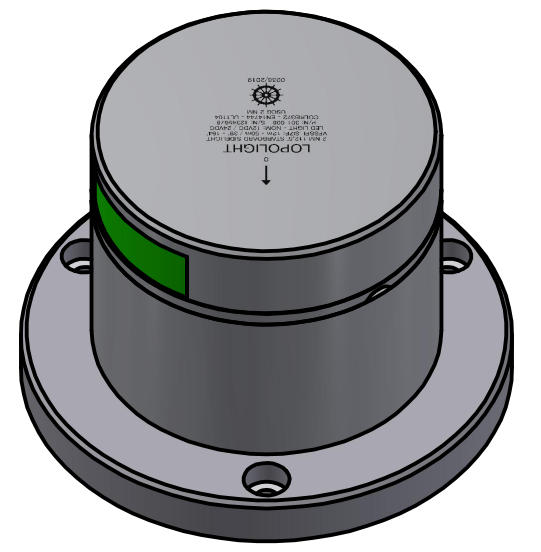
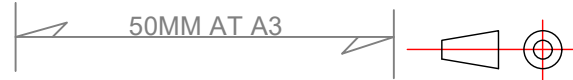

LOPOLIGHT
Lopolight ApS
Bakkegaardsvej 513
DK-3050, Humlebaek
Denmark
www.lopolight.com

Tel:(+45) 32 48 50 30
info@lopolight.com

A B C D E F G H I J

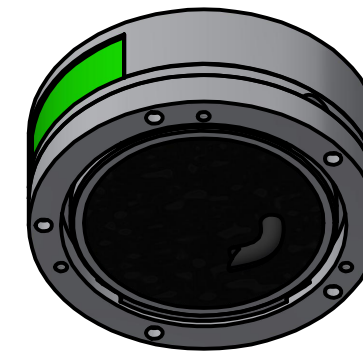
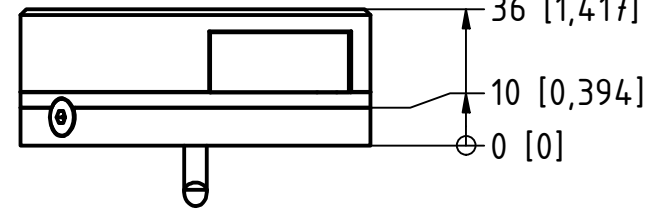
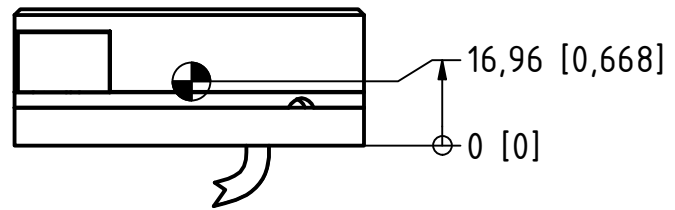
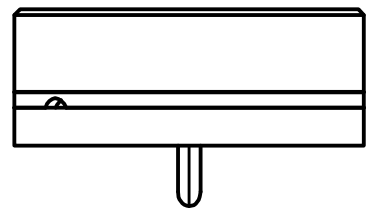

F ↑

F (1 : 2)

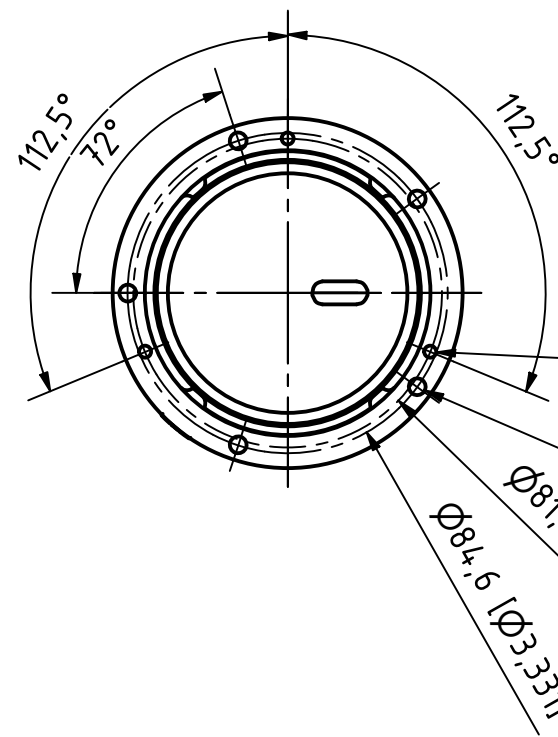

Mounting holes (Mount from underside)
3XM4x0.7 THRU

Mounting holes (Mount from top)
5x Countersunk for 4 mm
cylinderhead (DIN 912/ISO4762)

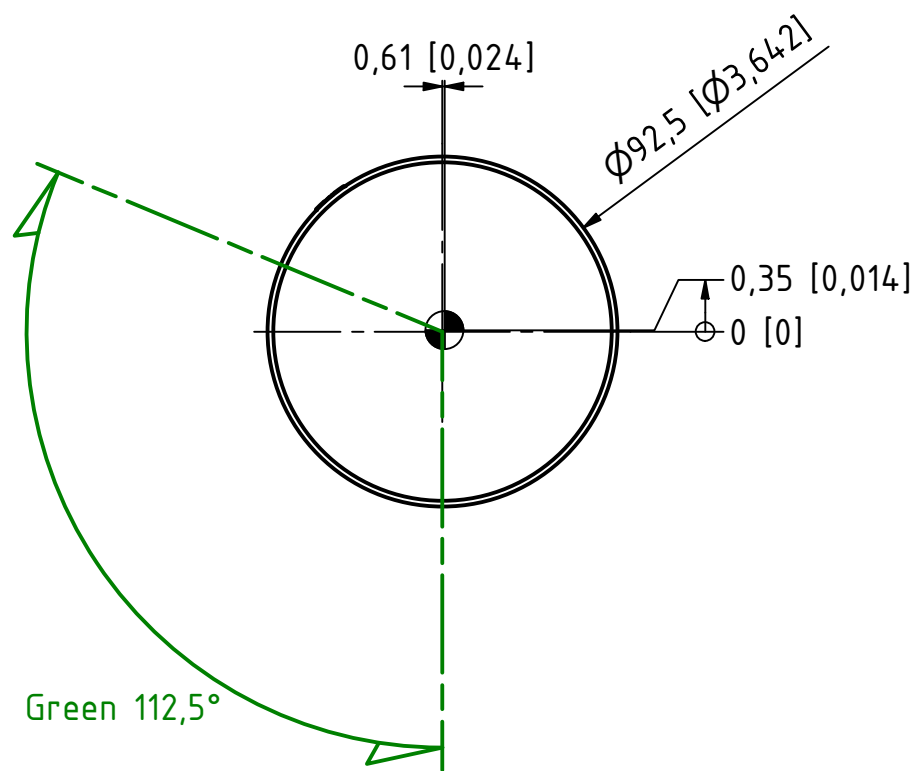

Dimensions : Millimetres [Inches]
Estimated weight: 0,5 kg (1 lbs)

TITLE: 301-008-WH-UL 2nm Stbd, white ceramic coated, UL On a 400-036 Ultra Low profile base					
DRAWING No.: 301-008-WH-UL			Sheet No.: 3	DRAWN BY: LSA	
SCALE: 1 : 2	SIZE: A3	REV. NO.:	TOLERANCES: DS/ISO 2768-f	REVIEWED BY:	CREATION DATE: 08-06-2023
MATERIAL DESCRIPTION: Alu. EN6082, Acrylic			(25µ) Silver anodized according to EN ISO 7599 (50µ) Black anodized according to MIL-A 8625F		



Lopolight ApS
Bakkegaardsvej 513
DK-3050, Humlebaek
Denmark
www.lopolight.com

Tel:(+45) 32 48 50 30
info@lopolight.com

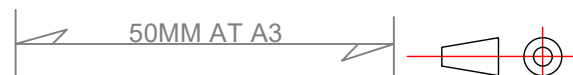

This Drawing, and the information within, is the property of Lopolight ApS and may not be used in any form without express permission there from. Lopolight reserves the right to change this drawing and assumes no liability for the information communicated herein. Use of dimensions and other information in this drawing is at the users own risk.